



RELIABLE
SCREEN SUPPLY

BARRIER-FREE PLEATED RETRACTABLE SCREENS



**TAIWAN
EXCELLENCE**



**GOLDEN PIN
DESIGN AWARD**

BARRIER FREE PLEATED SCREEN



PRODUCT FEATURES

The bottom track is only 3.5mm height which creates a barrier-free space.

The barrier-free design allows easy smooth access for prams, wheel chairs and bicycles.



1. Easy access



3. Magnetic click for more security



2. Easy assemble and clean

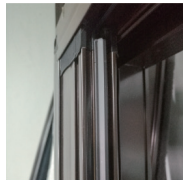

4. Stable gears for a smooth opening and closing

OPENING CONFIGURATION

Max (1 single panel) width : 89% out of existing height eg. h2000mm x 0.89 = w1780mm

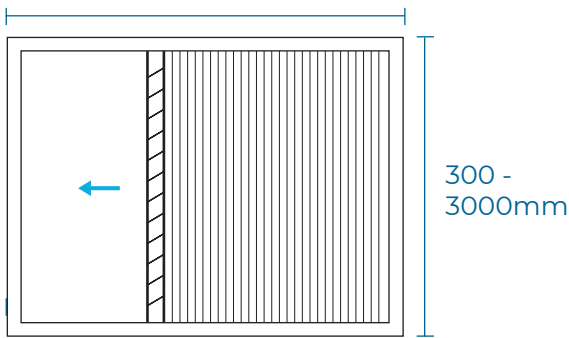

Single Slide

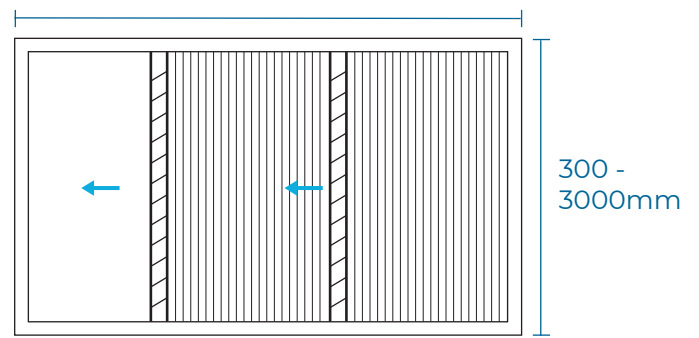

Double Slides Closing

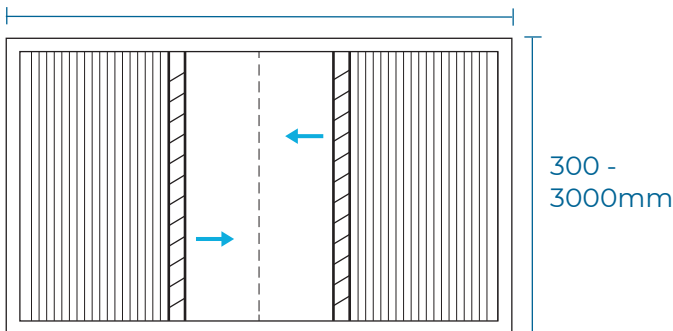

Double Slides Centre Closing

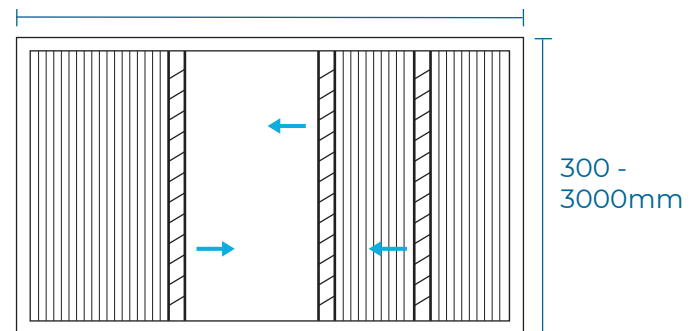

Multi Slides

PRODUCT DETAILS

Frame colour options

White / Black / Ivory / Brown8195 / Champagne Grey / Brown5101 / Silver Pearl / Clear Anodised
*Custom colour NOT available

Mesh colour options

Grey / Black

Mesh Material

(PE + PP), Midges proof (3 years warranty)

Frame Material

Powder coated aluminium (5 years warranty)

TECHNICAL SPECIFICATION

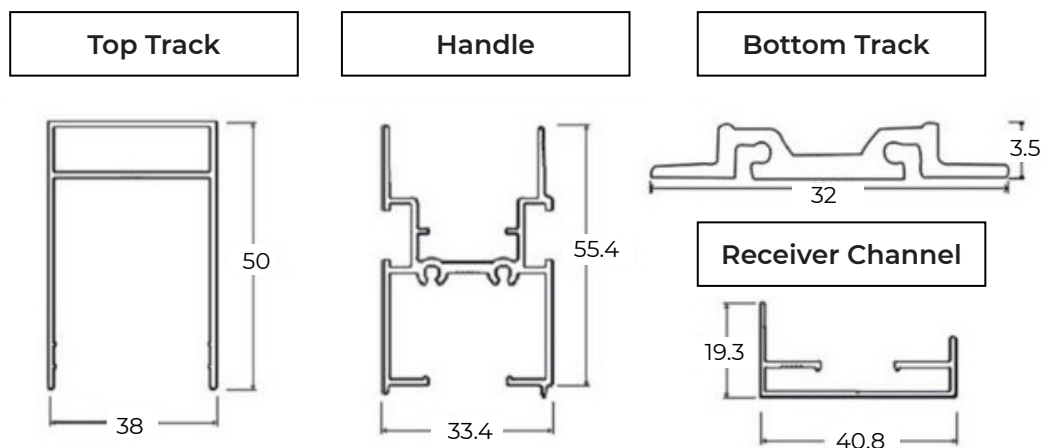



Find us on 



reliablescreensupply.com.au

RELIABLE SCREEN SUPPLY AUSTRALIA

Email [RSSaus1@gmail](mailto:RSSaus1@gmail.com) / **Showroom** 66 Merivale Street, South Brisbane
Website reliablescreensupply.com.au / **Facebook** Reliable Screen Supply

RELIABLE SCREEN SUPPLY NEW ZEALAND

Email hissnzau@gmail.com / **Phone** (09) 279 9869 / **Website** hiss.co.nz
Main office Unit 4, 23 Springs Road, East Tamaki, Auckland